

OPERATING MANUAL

MHS-3200A
Dual-channel
DDS Signal Generator

Unpacking

When you get a new MHS-3200A Series dual-channel DDS signal generator, it is recommended that you follow these steps to inspect the instrument.

1、 Check for transportation damage caused.

Such as packing or bubble bag cushions serious damage, keep them until the machine and accessories passed the test.

2、 Check the box in the article are complete.

The package contents as described below. If the content does not match or if the instrument is damaged, contact your dealer or manufacturer.

Host computer:	MHS-3200A Series dual-channel DDS signal generator	1
Accessory:	Power Adapter	1
	USB cable	1
	Signal connection cable	2
	User Manual (pdf version)	1

3. Check the machine

Inspect the instrument is damaged, not working properly, or fails performance tests, please contact your dealer or the Company.

1 .Outline

1-1. The instrument Introduction

MHS-3200A series instruments using large scale integrated circuits and high-speed FPGA MCU microprocessor, the internal circuit to take surface mount technology has greatly enhanced the instrument's noise immunity and service life. Display interface using LC1602 LCD display is divided into two lines, the top line shows the current frequency, the following line displays additional parameters or function variable and flexible use of flip key setting, greatly enhances the operability. This instrument signal generation, waveform scanning, as well as the use of parameter measurement has great advantages, is an electronic engineer, electronic laboratories, production lines and teaching, research and the ideal test, measurement equipment.

Model Description

This series of instruments in four models, the main difference is the maximum frequency sine wave, as follows:

- MHS-3200-06M sinusoidal signals at frequencies up to 6MHz
- MHS-3200-12M sinusoidal signals at frequencies up to 12MHz
- MHS-3200-20M sinusoidal signals at frequencies up to 20MHz
- MHS-3200-25M sinusoidal signals at frequencies up to 25MHz

The instrument characteristics

- 1、 Direct digital synthesis (DDS) technology, FPGA design, low power consumption;
- 2、 Dual output, can work in sync phase adjustable;
- 3、 It has up to 500 seconds of linear and logarithmic sweep function Sweep;
- 4、 With a sine wave, triangle wave, square wave, sawtooth rise, falling sawtooth waveform basic function and variable duty cycle pulse wave,
- 5、 A total of 10 sets of parameters stored bits have M0 ~ M9, M0 boot automatically transferred out of data;
- 6、 At 12MHz or less, the sharpest of up to 15Vp-p, more than 12MHz, the biggest reach 8Vp-p;
- 7、 Built precision -20dB attenuator reach the minimum amplitude resolution 1mV;

-
- 8、 With a 120% ~ + 120% DC bias function;
 - 9、 Pulse Duty precise adjustment to 0.1%;
 - 10、 Having four variable phase difference of TTL output;
 - 11、 Having a frequency measurement, period measurement, positive and negative pulse width measurement, duty cycle measurements and counting function;
 - 12、 Four optional gate frequency measurement time, which strike a balance between speed and accuracy;
 - 13、 All parametric equalizer can be done by an internal calibration procedure;
 - 14、 Powerful communications features, completely open communication protocol that allows the secondary development of very simple;
 - 15、 This type machine can be equipped with an increase in power module, the signal output amplitude reaches 30Vpp, the maximum output current reaches 1A;

Technical indicators

Table 1-1 MHS-3200A Series Specifications

Project		Parameters	
Key Features	Frequency Range	Sine wave	Normal mode: MHS-3200-06M: 0Hz~6MHz; MHS-3200-12M: 0Hz~12MHz; MHS-3200-20M: 0Hz~20MHz; MHS-3200-25M: 0Hz~25MHz。
		Square wave	0Hz~6MHz
		Triangle wave	0Hz~6MHz
		Sawtooth	0Hz~6MHz
		Arbitrary Waveform	0Hz~6MHz
		TTL Digital signal wave	0Hz~6MHz
	Output modulation	Frequency sweep	
	Waveform types	Sine, square, triangle, sawtooth lift, TTL digital signal wave,	
	Waveform Length	1024 Point	
	Sampling rate	200MSa/s	
	Waveform amplitude resolution	8bits	
The minimum frequency	10mHz		

	resolution	
	Frequency error	$\pm 5 \times 10^{-6}$
	Frequency stability	$\pm 1 \times 10^{-6}$
	Amplitude range (peak to peak)	15mVp-p~15Vp-p(12MHz or less) 15mVp-p~8Vp-p(12MHz above)
	Output Impedance	50Ω±10%
	Amplitude resolution	1mVp-p (-20dB Attenuation) 10mVp-p (Does not decay)
	Amplitude stability	±0.5% (Every five hours)
	Amplitude error	± 1%+10mV (Frequency 1KHz, 15 Vp-p)
	Offset Range	-120%~+120% (The ratio of the bias voltage and signal amplitude)
	Bias Resolution	1%
	Phase range	0~359°
	Phase resolution	1°
Sine wave	Harmonic arrived System	40dBc(<1MHz) ,35dBc(1MHz~20MHz)
	Distortion	<0.8%(20Hz~20KHz)
Square wave	Lifting along time	≤20ns
	Overshoot	≤10%
	Duty cycle adjustment range	0%~99.9%
TTL	Lifting along time	≤20ns
	LOW	<0.3V
	High	1V~7.5V
Scan	Scan Mode	Linear sweep, log sweep
	Scan time	1S~500S
	Scan range	It is determined by the sweep parameter settings
External measurements	Frequency range	GATE-TIME=10S 0.1HZ - 60MHZ GATE-TIME=1S 1HZ - 60MHZ GATE-TIME=0.1S 10HZ - 60MHZ GATE-TIME=0.01S 100HZ - 60MHZ
	Input voltage range	0.5Vp-p~20Vp-p
	Counting range	0~4294967295
	Counting	Manually
	Positive and negative pulse width measurement	10ns resolution, the maximum measurable 10s

	Periodic measurements	20ns resolution, the maximum measurable 20s
	Duty Cycle Measurement	0.1% resolution, measuring range from 0.1% to 99.9%
	Source Selection	1.Ext.IN input (AC signal), 2.TTL_IN input (digital signal)
Memory	Memory	10
	Location	M0-M9
Interface	Interface	Using USB to serial interfaces
	Communication rate	57600bps
	Protocol	Using the command line, the agreement public
Power supply	DC	DC 5V
Size	Length × width × height	180×190×71mm
Weight	Single	546g

Instrument Description

1、Panel

MHS-3200A Appearance Figure 2-1 shows the description of the parts as shown in Table 2-1. Figure 2-1 MHS3200A panel

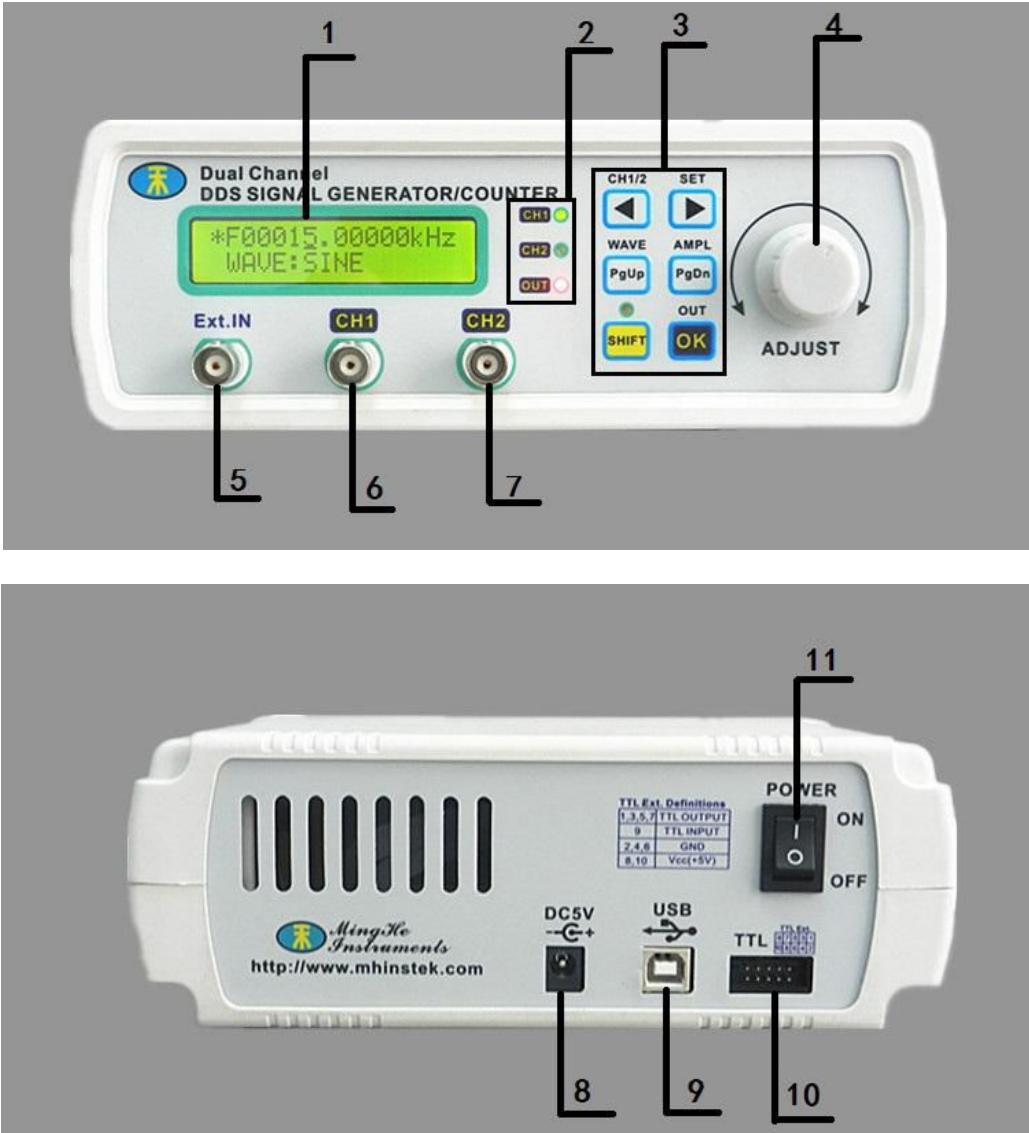

Table 2-1 MHS3200A Panel

Grade	Explanation	Grade	Explanation
1	LCD1602	7	CH2 output interface
2	Status Indicator	8	DV5V power input
3	Operation buttons	9	USB

4	Knob	10	TTL input / output interface
5	Ext.In input interface		
6	CH1 output interface	11	Switch

2、Ribbon Description

LCD instrument display is divided into two functional areas, as shown in Figure 2-2, description of the parts shown in Table 2-2.

Figure 2-2 MHS3200A schematic display

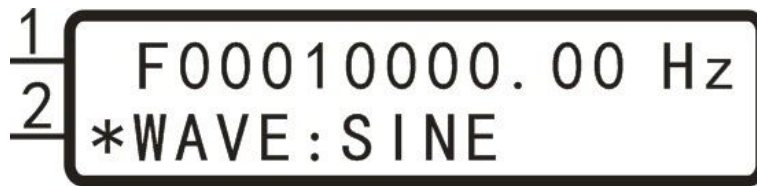



Table 2-2 MHS3200A Ribbon Description

Grade	Ribbon Description
1	Frequency Display
2	Operation Feature Tip

3、Key Functions

	Cursor left adjustable parameters of the step value
	Move the cursor right step to reduce the adjusted parameter value
	Page Up key function selection
	Function selection Page down
	OK button
	Channel switch (CH1 \ CH2)
	Switching position, when the "*" when the "*" second line adjustment options to adjust the frequency of the first line,
	Click this button to quickly enter a combination of waveform adjustment
	Click this button to quickly enter a combination of amplitude modulation

	Click this button to turn on or off output combination
---	--

Instructions

Power

- 1、 Access 5V supply. You can use the box to configure oriented instrument powered DC5V power adapter.
- 2、 Enter the main interface.



Instructions

This section will detail how to operate the instrument. It should be noted that, similar to the instrument channel CH1 CH2 channel with which the operating instructions section 1-6 also apply to CH2 channel.

1、 Set the CH1 waveform



Drawing 2-3

In the main interface shown in Figure 2-3, when the "*" in the first line , Click  Bond Adjust the output waveform type, the output waveform types are sine, square, triangle, rising sawtooth, descending sawtooth wave and a 16-Group on Arbitrary, Press  Key it is possible to return ahead of the original set of waveform,

If you want to quickly adjust the output waveform can click , Then a "*" to switch to the second row, rotating "ADJUST" knob, you can quickly switch the output waveform types.

2、 Set the CH1 frequency

In the main interface, shown in Figure 2-4 when the "*" in the first line, By







adjusting  or  Move the cursor to adjust the frequency step size, Then to adjust the frequency of the output waveform by rotating the "ADJUST" knob.



图 2-4

3、Setting the amplitude of CH1

In the main interface, Press  +  Button after, The magnitude of the interface will appear in a cursor set, Click  or  Button, It is possible to move the cursor position, rotate "ADJUST" knob to adjust the amplitude of the output waveform, as shown below:

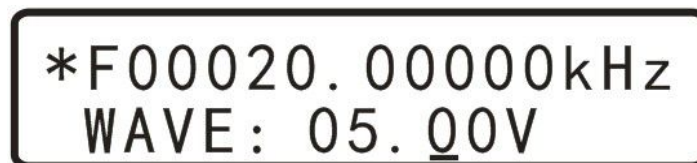

Drawing 2-5

Wherein, 05.00V refers peak to peak. In this range setting function mode, the maximum amplitude of 15V, minimum 0.15V, the minimum step value 0.01 (10mV); as shown in a state 2-6, Press  -20dB Attenuation state of the incoming signal, the output signal of a maximum of 1.500V, the minimum value of 0.015V, the minimum step is 0.001V (1mV).









图 2-6

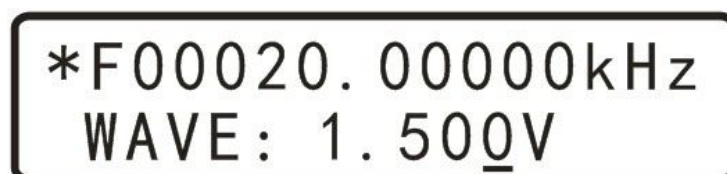



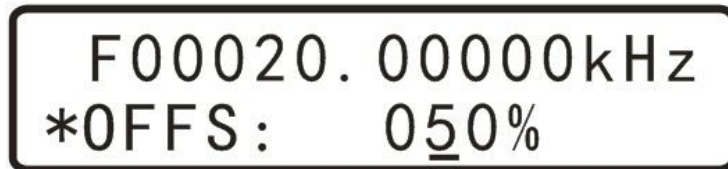

4、Setting bias of CH1

In the main interface, Press  或 , Adjusted to offset adjustment options shown in Figure 2-7, Then click  + , The "*" are switched to the second row, Click  or  To move the cursor, Then "ADJUST" knob to adjust the offset parameter.



Drawing 2-7





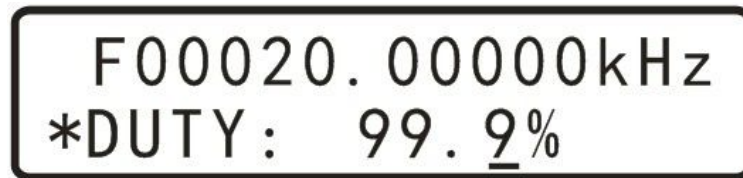

5、 Duty cycle setting CH1

In the main interface, Press  or , Adjusted to duty cycle adjustment options shown in Figure 2-8, Then click  + , The "*" are switched to the second row, click  or  To move the cursor, Then "ADJUST" knob to adjust the offset parameter.



Drawing2-8

5、 Setting the phase difference between the two channels

In the main interface, Press  or , Adjusting the phase adjustment options shown in Figure 2-9, Then click  + , The "*" are switched to the second row, Click  or  To move the cursor, Then "ADJUST" knob to adjust the bias parameter, you need special note is the phase difference only in the same frequency CH1 and CH2 frequency when it makes sense.



Drawing 2-9

6、 Setting the display unit of frequency











In the main interface, Press  or , Adjusted to the frequency display unit adjustment options shown in Figure 2-9, Then click  + , The "*" are switched to the second row, Then click  Switching frequency units Hz、kHz、MHz。



图 2-10

7、 Tracking

Tracking function is used to synchronize the frequency of CH2 to CH1, and users can set the amplitude of the tracking and duty track, In the main interface, Press  or , Adjusted to tracking options shown in Figure 2-11, Then click  + , The "*" are switched to the second row, and then click  Switched ON or OFF state. When the tracking function is turned frequency automatic tracking frequency channel CH2 CH1 channel. Also, before turning if tracing, CH1 and CH2 channel amplitude is the same tracking feature is turned on CH1 and CH2 frequency automatic tracking; if the duty is the same as CH1 and CH2 are turned on after tracing CH1 and CH2 account empty than automatic tracking.



Drawing 2-11

8、 External signal input port selection











Select the input signal Ext.IN for input AC signal, Select TTL.IN for selecting the input digital signal wave. In the main interface, Press  or , Adjust to the input port selection page, Then click  + , The "*" are switched to the second row, Then click  Key switch input port selection Ext.IN or TTL.IN.



图 2-12

9、 Measurement function

In selecting the input source later, the input signal can be measured a variety of parameters.

(1) In the main interface, Press  or , Adjusted to the measurement function selection page shown in Figure 2-13, Then click  + , The "*" are switched to the second row, Then click  Bond Switch the output port selection measurement object. **FREQ.** (Frequency)、 **COUNTR**(Counting function)、 **POS-PW**(+ Width)、 **NEG-PW**(Negative Pulse Width)、 **PERIOD**(Cycle)、 **DUTY** (Duty cycle)。



Drawing2-13

(2) After determining the measurement object, Click , Enter gate time selection page as shown below:

(3) Click  Bond, Select a different gate time 10S, 1S, 0.1S, 0.01S, different gate time on the frequency measurement accuracy and measurement speed.



Drawing 2-14

(3) Gate time is determined, Click , Enter the measurement results display. The page can display the input measurement results, such as frequency, duty cycle, pulse width, and so the cycle parameters.

10、 sweep function

(1) Adjusted to start frequency sweep function settings page, and then adjust the start frequency 5kHz. As shown below:





Drawing2-15



(2) Then click  Into the cut-off frequency sweep function settings page, and then adjust the cutoff frequency of 10kHz. As shown below:





Drawing2-16



(3) Then click  Enter sweep time setting page , Then click  The "*" are switched to the second row , Rotation "ADJUST" knob to adjust the sweep time, frequency arbitrarily set the time range between 1-600S, shown in the lower set sweep time 10S:



(4) Then click  Enter sweep mode selection screen shown in Figure 2-22, Click  Bond Select the frequency scan mode 。 There are two ways to scan frequency, LINE (linear scanning) and LOG (logarithmic sweep).

(5) After determining the scan mode, Click  Enter sweep control page, Then click  on or off sweep function.

11、 Save / Load function

In the main interface, press  or  Enter the parameter to save the page, and then click  Press the key combination of "*" consumption is adjusted to the second row in Figure 2-11, then rotate "ADJUST" knob to adjust the save location, this machine a total of 10 sets of parameters stored addresses M0-M9. Machine is turned on by default to read M0 address parameters.





图 2-16

In the main interface, press  or  Enter the parameter to call up the page, then click  Press the key combination of "*" consumption is adjusted to the second row in Figure 2-12, then rotate "ADJUST" knob to adjust the save location, this machine a total of 10 sets of parameters stored addresses M0-M9. Machine is turned on by default to read M0 address parameters.

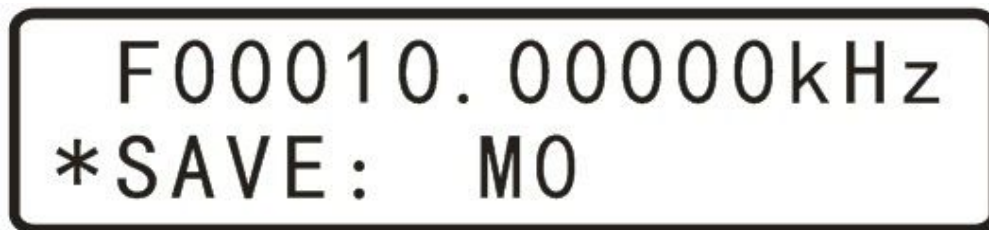

图 2-17

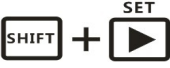
12、 Calibration function

Calibration function is we do a job at the factory, you can consult the factory calibration is required.

Chapter Four PC Instructions

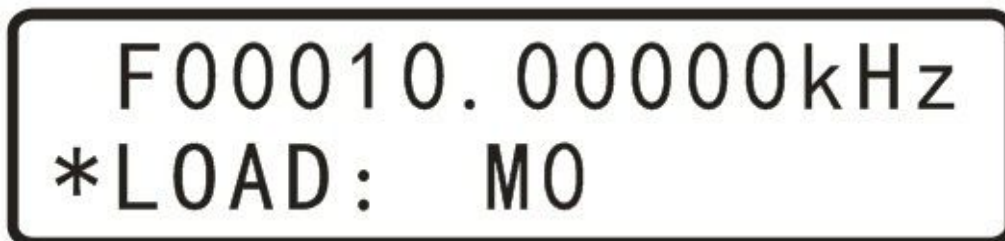
1、 install software

- Step 1: Install the runtime software visa540_runtime.exe
- Step 2: Install CH341SER the SETUP.exe serial to USB drivers
- Step 3: Install signal generator .exe program

2、 online

Step 1: Right-click Computer - Properties - Device Manager - observation assigned to the computer serial port

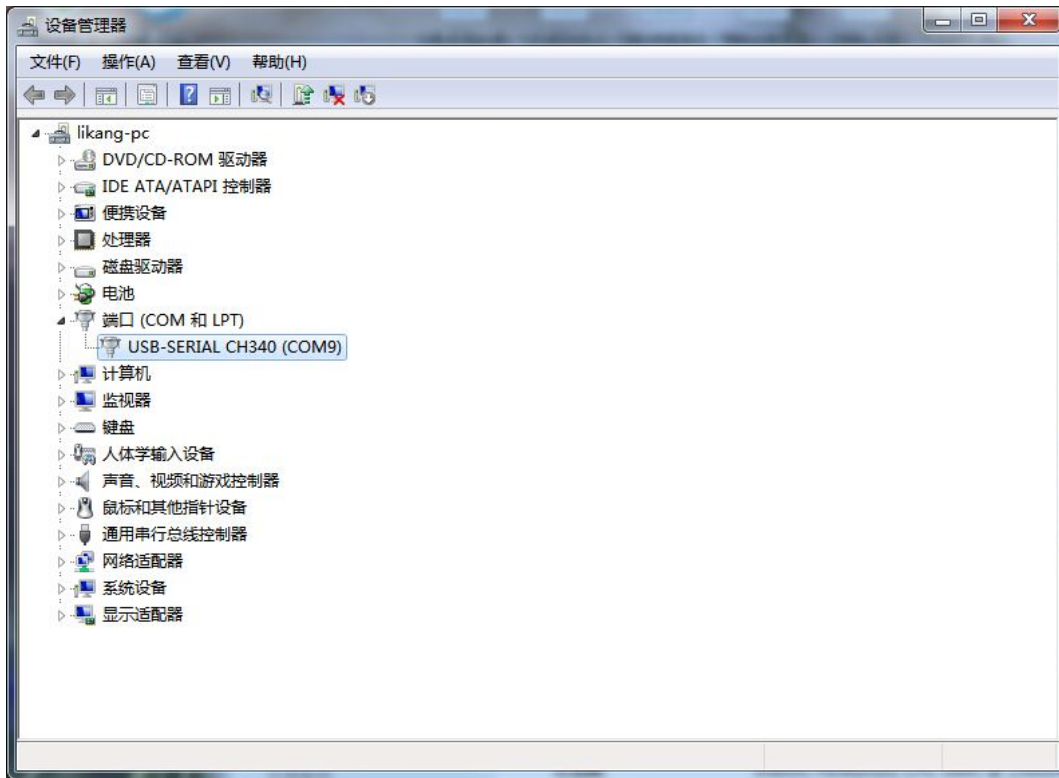

Step 2: Select the appropriate serial line after the point



Step 3: Online Success



Care and maintenance

1. Make sure the input power adapter correctly, the machine uses DC5V power adapter;
- 2, the instrument display on the LCD module is fragile, perishable items, please do not slam and near chemicals to prevent corrosion. When you feel the liquid surface dust and dirt, wipe with a soft cloth carefully.
- 3, the working temperature of $-10 \sim 50$ °C, Storage temperature $-20 \sim 70$ °C, and the instrument in a dry environment.
4. Do not attempt to disassemble the equipment, destroy the package will void the warranty. The instrument is there are no user-serviceable parts, repairs may only repair outlets or by specifying the return factory.
- 5, avoid lighted candles, a water cup, corrosive chemicals and other unsafe items placed on the surface of the instrument, so as not to cause damage to the instrument.
- 6, the display screen are easy to pollution, fragile device, do not touch the hand as well as external and collision, avoid children play this instrument.
7. Do not move the instrument to avoid severe irreparable damage to the internal circuit when the instrument is working properly.

Exclude the above problem re-power the instrument still does not work, please contact your supplier!